

HERCULES ***FITNESS***

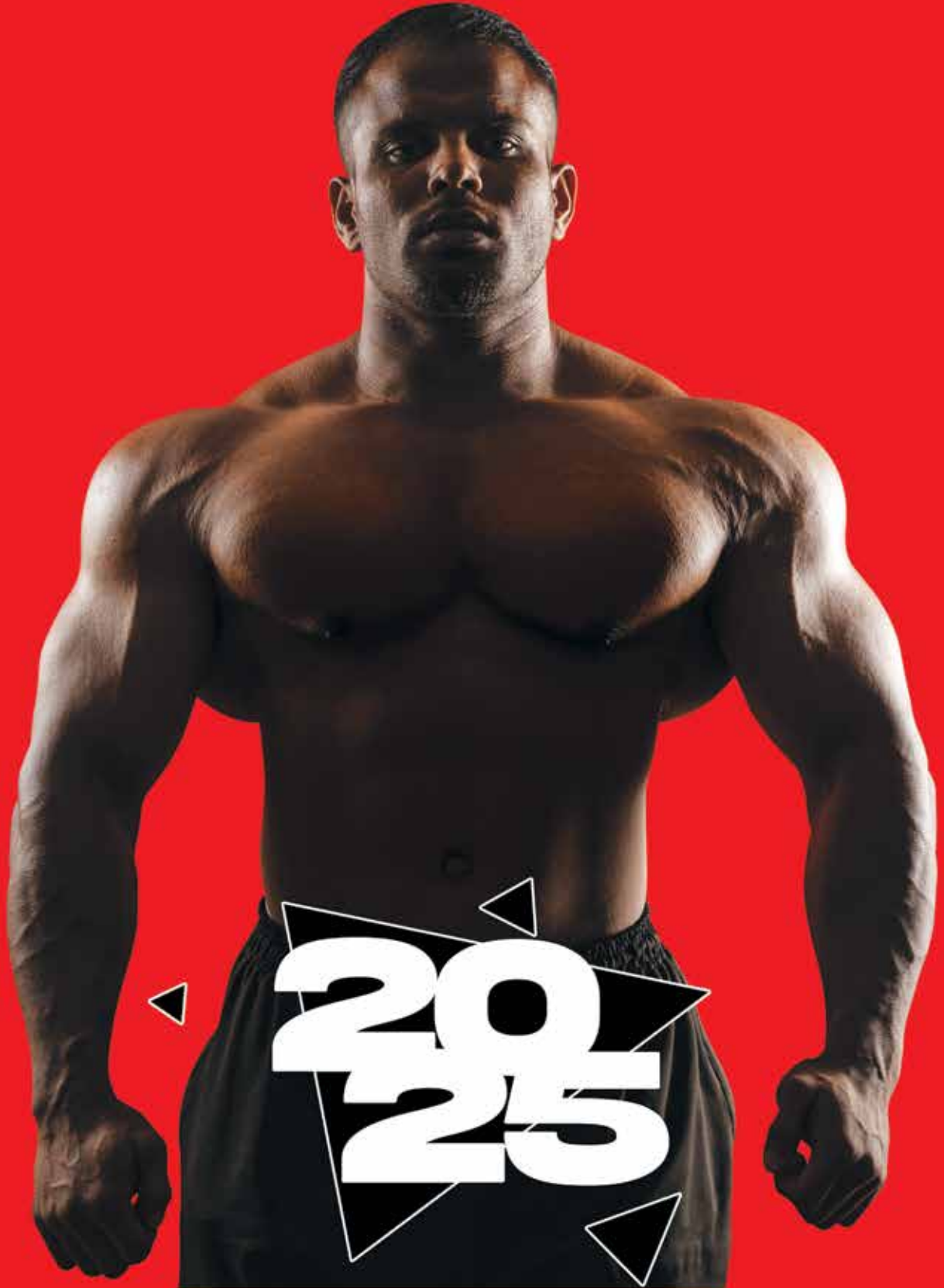

L I V E Y O U N G

A FAMILY OF EXCELLENCE



INDEX

SL. NO.	CONTENT	PAGE NO.
01.	ABOUT MURUGAPPA	4
02.	ABOUT TI.....	5
CARDIO		
03.	TREADMILL	8
04.	ELLIPTICAL TRAINER	21
05.	BIKES	26
06.	SKI.....	33
07.	ROW	34
PIN LOADED		
08.	DIOR	37
09.	ARISTO.....	42
10.	FORGE	47
11.	DNA	52
12.	APEX	57
13.	STOIC	61
14.	AURA	63
15.	GRIT.....	66
16.	FLEXION	70
17.	RAZOR	73
PLATE LOADED		
18.	ARMOUR	77
19.	STOIC.....	80
20.	AURA	82
21.	FUNCTIONAL, CABLE, SMITH & MULTI STATION	85
22.	FREE WEIGHT & BENCHES	102
23.	ACCESSORIES.....	112



FOUNDED 1900

29 BUSINESSES

53,000 EMPLOYEES

200+ EXCLUSIVE STORES

Founded in 1900, the INR 742 Billion (74,220 Crores) Murugappa Group is one of India's leading business conglomerates. The Group has 29 businesses including ten listed Companies traded in NSE & BSE. Headquartered in Chennai, the major Companies of the Group include Carborundum Universal Ltd., CG Power and Industrial Solutions Ltd., Cholamandalam Financial Holdings Ltd., Cholamandalam Investment and Finance Company Ltd., Cholamandalam MS General Insurance Company Ltd., Coromandel International Ltd., Coromandel Engineering Company Ltd., E.I.D. Parry (India) Ltd., Parry Agro Industries Ltd., Shanthi Gears Ltd., Tube Investments of India Ltd. and Wendt (India) Ltd. The Group holds leadership position in several product lines including Abrasives, Technical Ceramics, Electro Minerals, Auto Components & Systems, Bicycles, Fertilisers, Sugar, Tea and Spirulina (Nutraceuticals).

The Group has forged strong alliances with leading international companies such as Groupe Chimique Tunisien, Foskor, Mitsui Sumitomo, Morgan Advanced Materials, Yanmar & Co. and Compagnie Des Phosphat De Gafsa (CPG). The Group has a wide geographical presence all over India and spanning 6 continents. Renowned brands like BSA, Hercules, Montra, Mach City, Ballmaster, Ajax, Parry's, Chola, Gromor, Shanthi Gears and Paramfos are from the Murugappa stable. The Group fosters an environment of professionalism and has a workforce of over 53,000 employees.



Established in 1949 by the Murugappa Group in partnership with Tube Investments (UK), TI Cycles has rapidly transformed from a bicycle manufacturing company to an industry giant in mobility and well-being solutions.

Currently, TI Cycles is the key player in the 'Specials' segment with a nationwide presence bolstered by a network of around 11,500 primary and secondary dealers. The company's plants in Chennai and Rajpura possess the capacity to manufacture five million bicycles a year.

TI Cycles' flagship brands include BSA, Hercules, Montra and Mach City. The brand is credited with many of India's firsts - the first MTB, the first geared bike, the first Shox bike, the first girls' bike, the first kids' bike, the first light Roadster, and the first carbon frame bike.

The past seven decades have witnessed TI Cycles evolve into a powerhouse that's constantly making headway to meet the consumer's needs, from innovative products to futuristic design to unique retail formats.

TREADMILL



Treadmills provide a straightforward and efficient aerobic workout. For many, treadmills are a good choice to begin a new exercise routine because most individuals can take up walking regardless of fitness level and back condition. As strength and endurance develops, the treadmill can be used for jogging and/or for interval training.

TREADMILL

TA900



LED Display

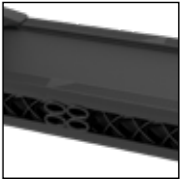

Cushion

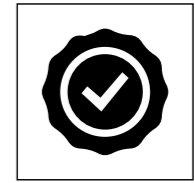

Lifetime Warranty
for Motor



RHYMEBUS

Technical Features

Display: Led Screen

Machine Size: 87" x 36" x 67"

Speed: 1-20km/h

Running Area: 60"*24"

20 Level Automatic Motorized Incline

Machine Weight: 180kg

Maximum User Weight: 250kg

Display Reading: Speed, Time, Calories, Distance & Heart Rate

Motor Power: 4.5/9.0 HP Peak AC Motor

TA800



LED Display



RHYMEBUS



Lifetime Warranty for Motor

Technical Features

Display: Led Screen

Machine Size: 87" x 36" x 64"

Speed: 1-20km/h

20 Level Automatic Motorized Incline

Running AREA: 60*23

Machine weight: 187kg

Maximum user weight: 200kg

Display Reading: Speed, Time, Calories, Distance & Heart Rate

Motor Power: 4.0/8.0 HP Peak AC Motor

TA700

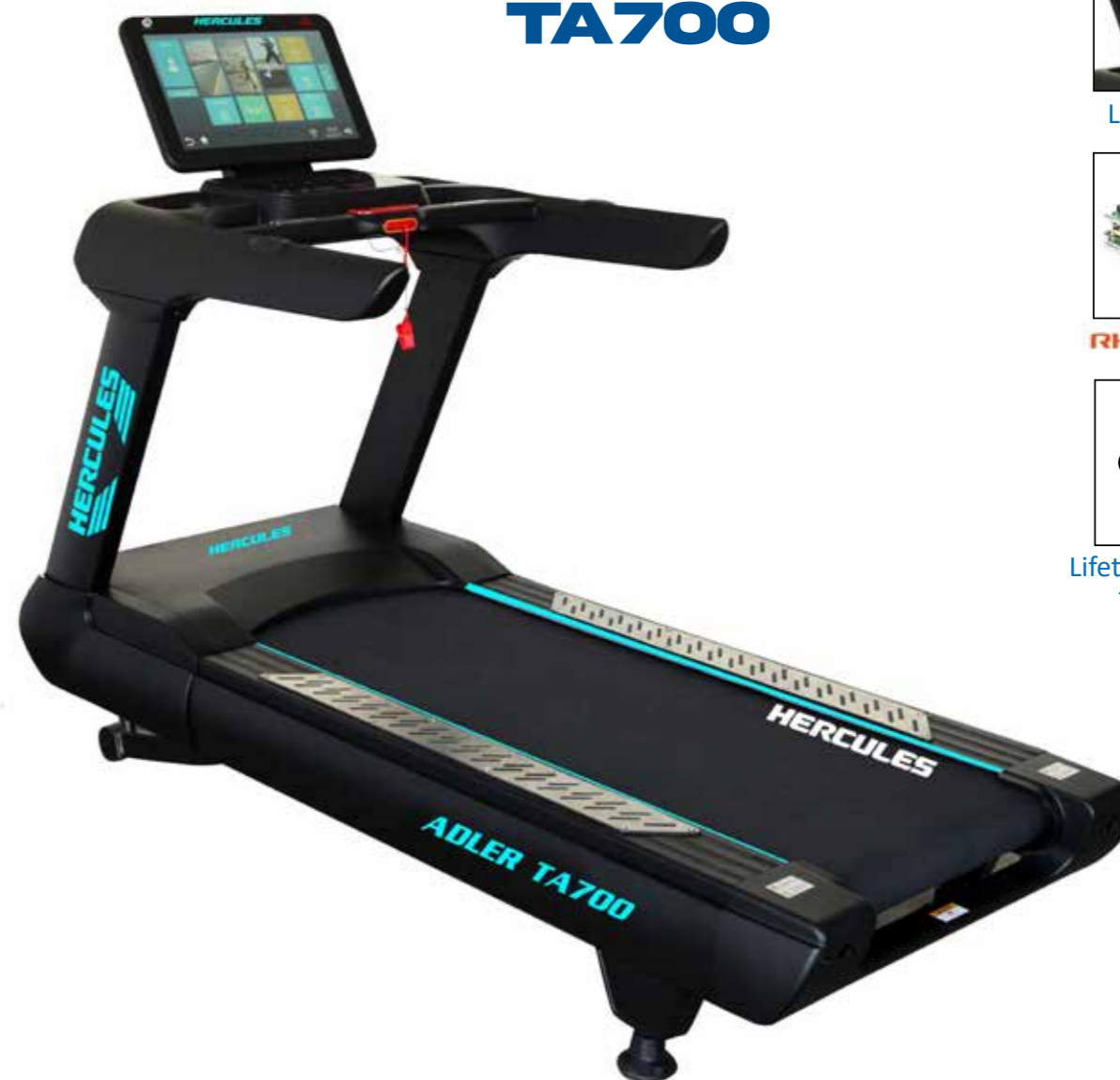

LED Display



RHYMEBUS

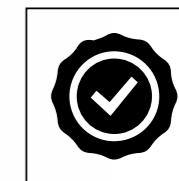

Lifetime Warranty for Motor

Technical Features

Machine Floor Size: 95" x 40" x 70"

Taiwanness Rhymebus Inverter

Speed: 1-25km/h

15 Level Automatic Motorized Incline

65" x 24" Extra Wide Running Area

Maximum User Weight: 250 Kgs

Machine Weight: 270 Kgs

Un-Foldable Structure

Heart Rate Measurement

Motor Power: 4.5 H.P / 9 H.P AC MOTOR

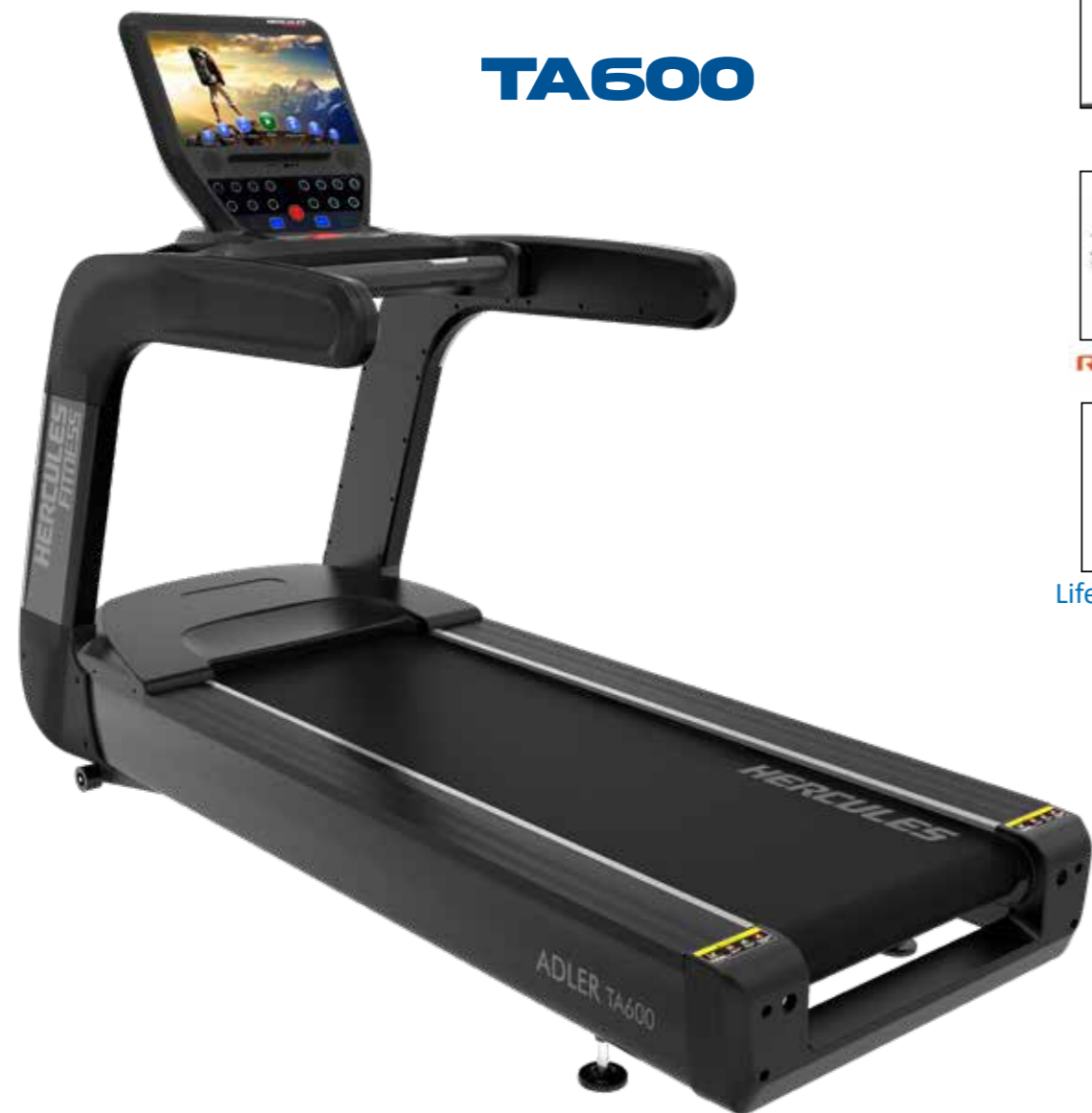

TA600



LED Display



RHYMEBUS



Lifetime Warranty for Motor



TA580



LED Display



RHYMEBUS



Lifetime Warranty for Motor

Technical Features

Display: Led Screen

Machine Size: 87" x 36" x 64"

Speed: 1-20km/h

15 Level Automatic Motorized Incline

Running AREA: 60*24

Machine weight: 187kg

Maximum user weight: 200kg

Display Reading: Speed, Time, Calories, Distance & Heart Rate

Motor Power: 4.0/8.0 HP Peak AC Motor

Technical Features

Display: LED Screen

Machine Size: 80" x 37" x 62"

Speed: 1-20km/h

15 Level Automatic Motorized Incline

Running Area: 59*24

Machine Weight: 178kg

Maximum User Weight: 200kg

Display Reading: Speed, Time, Calories, Distance & Heart Rate

Motor Power: 4.0/8.0 HP Peak Ac Motor



TMA80



LED Display



RHYMEBUS



Lifetime Warranty for Motor

Technical Features

- Machine Floor Size: 95" x 38" x 69"
- 20 Level Automatic Motorized Incline
- 25 Km/hr. Max. Speed
- Pre-set Workout Programs
- Hand Held Heart Rate Sensor
- Maximum User Weight: 250 Kgs
- Machine Weight: 285 Kgs
- 65" x 24" Extra wide running area
- Anti-Static Running Belt
- Display Reading: Speed, Time, Calories, Distance & Heart Rate

Motor Power: 4.5 H.P / 9 H.P AC MOTOR



TA350 Technical Features

- Machine Floor Size: 83" x 36" x 56"
- 22 Km/hr. Max. Speed
- 15 Level Automatic Motorized Incline
- 61" x 22" Extra Wide Running Area
- Maximum User Weight: 200 Kgs
- Machine Weight: 160 Kgs
- Un-Foldable Structure
- Display Reading: Speed, Time, Calories, Distance & Heart Rate
- Heart Rate Measurement

Motor Power: 4 H.P / 8 H.P AC MOTOR



TA300 Technical Features

- Machine Floor Size: 82" x 39" x 63"
- 25 Km/hr. Max. Speed
- 20 Level Automatic Motorized Incline
- 63" x 24" Extra Wide Running Area
- Maximum User Weight: 200 Kgs
- Machine Weight: 196 Kgs
- Un-Foldable Structure
- Display Reading: Speed, Time, Calories, Distance & Heart Rate
- Heart Rate Measurement

Motor Power: 3.5 H.P / 7 H.P AC MOTOR



TMA71 Technical Features

- 20 Km/hr. Max. Speed
- 20% level auto Incline
- Product Size: 2200 x 1020 x 1700 mm
- 65" x 24" Extra wide running area
- Maximum User Weight: 200 Kgs
- Machine weight 280 kgs
- Rubber Cushion – Accept the shock & less impact
- Display Reading: Speed, Time, Calories, Distance & Heart Rate
- High-end hardware configuration
- Motor Power: 4.0 H.P / 8.0 H.P AC Motor**



TMA65 Technical Features

- Large LED Display - Time, Distance, Speed, Calorie, Pulse & Pre-Set Workout Programs
- 20 Km/hr. Max. Speed
- 15 Level Automatic Motorized Incline
- Machine Floor Size: 90" x 37" x 63"
- 64" x 21" Extra wide running area
- Maximum User Weight: 200 Kgs
- Machine Weight: 225 Kgs
- Un Foldable Structure
- Rubber Cushion – Accept the shock & less impact on joints
- High-end hardware configuration
- Motor Power: 4.0 H.P / 8.0 H.P AC Motor**



TA270 Technical Features

- Machine Floor Size: 81" x 35" x 63"
- 22 Km/hr. Max. Speed
- 15 Level Automatic Motorized Incline
- 61" x 22" Extra Wide Running Area
- Maximum User Weight: 200 Kgs
- Machine Weight: 166 Kgs
- Heart Rate Measurement
- Display Reading: Speed, Time, Calories, Distance & Heart Rate
- Anti-Static Running Belt
- Motor Power: 3.5 H.P / 7 H.P AC MOTOR**



TMA71L Technical Features

- Unfoldable Structure
- 20 Km/hr. Max. Speed
- Running Area: 63" x 24"
- Machine Weight: 220 Kg
- Display Reading: Speed, Time, Calories, Distance & Heart Rate
- Motor Power: 4.0 H.P / 8.0 H.P AC Motor**



TMA64 Technical Features

- 20 Km/hr. Max. Speed
- Machine Floor Size: 83" x 35" x 64"
- Running Area: 61" x 23"
- Unfoldable Structure
- Maximum User Weight: 200 Kgs
- Machine Weight: 160kg
- Rubber Cushion – Absorb the shock & less impact on joints
- Display Reading: Speed, Time, Calories, Distance & Heart Rate
- Motor Power: 4.0 H.P / 8.0 H.P AC Motor**



TMC90 Technical Features

- Running Area: 63" x 19"
- Machine Weight: 160kg
- Maximum User Weight: 180kg
- Display Reading: Speed, Time, Calories, Distance & Heart Rate
- Machine Size: 76" x 35" x 61"



TMA65L Technical Features

- Machine Floor Size: 87" x 39" x 65"
- Unfoldable Structure
- Maximum User Weight: 200 Kgs
- Machine Weight: 193 Kg
- Display Reading: Speed, Time, Calories, Distance & Heart Rate
- Motor Power: 3.5 H.P / 7.0 H.P AC Motor**



TMC70 Technical Features

- LCD Display - Time, Distance, Speed, Calorie
- Magnetic Resistance Adjustment
- Machine Floor Size: 80" x 36" x 61"
- 59" x 18" Extra wide running area
- Maximum User Weight : 180 Kgs
- Machine Weight: 170 Kgs
- Un Foldable Structure
- Drive mode : Gravity
- Display Reading: Speed, Time, Calories, Distance & Heart Rate
- High-end hardware configuration
- Aluminium Alloy Crawler Belt



TA150 Technical Features

Machine Floor Size: 78" x 37" x 60"

20 Km/hr. Max. Speed

20 Level Automatic Motorized Incline

60" x 22" Extra Wide Running Area

Maximum User Weight: 190 Kgs

Machine weight: 132 Kgs

MP3&USB

Un- Foldable Structure

Display Reading: Speed, Time, Calories,
Distance & Heart Rate

Heart Rate Measurement

Motor Power: 3 H.P / 6 H.P AC MOTOR

ELLIPTICAL TRAINER



Elliptical trainers offer a non-impact cardiovascular workout that can vary from light to high intensity based on the speed of the exercise and the resistance preference set by the user.

ELS90



Technical Features

Display: LCD

Flywheel: 25 kg

Machine Weight: 155 kg

Maximum User Weight: 150kg

Machine Size: 83" x 28" x 69"

Stride Length - 22 Inches

Resistance: 20 Resistance Level

Programs: Manual, Roller, Climb, Interval, Weights Loss, Fat Burn

Display Reading: Speed, Time, Calories, Distance, Watt, Pulse, Rpm

Advance ECB Magnetic Resistance System

ELS80



Technical Features

Display: LCD

Flywheel: 23 kg

Machine Weight: 120 kg

Maximum User Weight: 150kg

Machine Size: 82" x 31" x 66"

Stride Length - 22 Inches

Resistance: 26 Resistance Level

Programs: Manual, Roller, Climb, Interval, Weights Loss, Fat Burn

Display Reading: Speed, Time, Calories, Distance, Watt, Pulse, Rpm

Advance ECB Magnetic Resistance System

ELS65



Technical Features

Machine Floor Size: 78" x 24" x 66"

Self Generator System

Stride Length 21 Inches

High Strength steel frame & Ultra stable structure

Hand Held Heart Rate Sensor

18 Kgs Fly wheel

Display Reading: Speed, Time, Distance, Pulse, Calories, User Program, Watt, H.R.C, Recovery, Body Fat, Speaker, USB Charging

EMS Generating System 32 Levels resistance

Net Weight/KG: 135kg

Max User Weight: 180Kgs

Drive: Self generator



ELS65L Technical Features

Display: LED

Flywheel: 20kg

Machine Weight: 135kg

Maximum User Weight: 150kg

Machine Size: 78" x 24" x 66"

Programs: Manual, Roller, Climb, Interval, Weights Loss, Fat Burn

Display Reading: Speed, Time, Calories, Distance, Watt, Pulse, Rpm



ELP70 Technical Features

Upper and Lower Body

Auto Electro Magnetic Resistance Control

16 Kgs Fly Wheel

Single Window Display - Time, Distance, Speed, Calorie, RPM, Pulse & Body Fat

Stride Length - 21 Inches

Machine Floor Size: 88" x 31" x 71"

Hand Held Heart Rate Sensor

Maximum User Weight: 170 Kgs

Drive: Electro Magnetic System

BIKES



An exercise bicycle is usually a special-purpose exercise machine resembling a bicycle without true wheels. The low-impact movement involved in operating an exercise bike does not put much stress on joints and does not involve sporadic motions that some other fitness equipment may require.

BIKES



RBS80 Technical Features

Display: LED

Flywheel: 17 kg

Machine Weight: 86 kg

Machine Size: 69" x 29" x 58"

Maximum User Weight: 150kg

Program: 10 Programs

Display Reading - Speed, Time, Calories, Distance, Watt, Pulse, Rpm

Resistance Level: 25 Levels



RBS90 Technical Features

Display: LED

Flywheel: 17kg

Machine Weight: 64 kg

Maximum User Weight: 150kg

Machine Size: 65" x 28" x 54"

Machine Weight: 150 kg

Resistance Level: 26 Levels



RBP70 Technical Features

Auto Magnetic Resistance Control

Fly Wheel: 16 Kgs

Single Window Display - Time, Distance, Speed, Calorie, RPM, Pulse & Body Fat

Hand Held Heart Rate Sensor

Machine Floor Size: 60" x 26" x 52"

High Strength steel frame & Ultra stable structure

Maximum User Weight: 170 Kgs

Drive: Electro Magnetic System



UBS90 Technical Features

Flywheel: 20kg

Machine Weight: 65kg

Maximum User Weight: 150kg

Machine Size: 45" x 21" x 59"

Program: 10 Programs

Display Reading: Speed, Time, Calories, Distance, Watt, Pulse, Rpm

Resistance Level: 26 Levels



UBS80 Technical Features

Flywheel: 17 kg

Machine Weight: 63 kg

Maximum User Weight: 150kg

Machine Size: 48" x 29" x 62"

Program: 10 Programs

Display Reading - Speed, Time, Calories, Distance, Watt, Pulse, Rpm



UBP70 Technical Features

Auto Magnetic Resistance Control

Fly Wheel 16 Kgs.

Machine weight-50kgs

Hand Held Heart Rate Sensor

Maximum User Weight: 170 Kgs.



SB90 Technical Features

- Flywheel: 22kg
- Machine Weight: 65kg
- Maximum User Weight: 180kg
- Machine Size: 41" x 24" x 45"
- Adjustment Lever (1-5-Level)
- Advance ECB Magnetic Resistance System



SB60 Technical Features

- Flywheel: 20 kg
- Machine Weight: 52 kg
- Maximum User Weight: 150kg
- Machine Size: 48" x 25" x 46"
- Adjustment Lever (1-5-Level)



SB80 Technical Features

- Flywheel: 23 kg
- Machine Weight: 86 kg
- Maximum User Weight: 150kg
- Machine Size: 66" x 27" x 57"
- Adjustment Lever (1-5-Level)



SB41 Technical Features

- Fly Wheel: 20 Kgs
- Single Window Display - Time, Distance, Speed & Calorie
- Machine Floor Size: 52" x 22"x 44"
- Heavy Duty 3 Pcs. Crank Design
- Maximum User Weight: 150 Kgs
- Drive: Belt Drive



SB35 Technical Features

- Brush Brake Resistance Control
- Belt Drive
- Heavy duty 3 piece Crank
- Machine Floor Size: 52" x 22"x 44"
- Precise Bearing for smooth function
- High Strength steel frame & Ultra stable structure
- Super Quiet Poly V belt Drive for smooth function
- 23 Kgs Fly wheel
- Maximum User Weight: 150 Kgs
- Drive: Belt Drive**



SKI90 Technical Features

- Machine Size: 51" x 24" x 84"
- Machine Weight: 45kg
- Maximum User Weight: 150g
- Display: Speed, Time, Distance & Calories



AB90 Technical Features

- Machine Weight: 74 Kgs
- Maximum User Weight: 150 Kgs
- Size: 51" x 23" x 48"



SKI60 Technical Features

- Display: Speed, Time, Distance & Calories
- 10 Level Manual Resistance
- Machine Floor Size: 52" x 24" x 85"
- Machine Weight: 50Kg



AR90 Technical Features

- Display - Lcd Display
- Display Reading - Resistance Level, Time, Distance, Stoke
- Programs - 10programs
- Max User Weight - 180kg
- Machine Weight - 50kg
- Machine Size - 105*20*45



AR60 Technical Features

- Display - Lcd Display
- Display Reading - Resistance Level, Time, Distance, Stoke
- Programs - 8programs
- Max User Weight - 130kg
- Machine Weight - 45kg
- Machine Size - 91*20*26

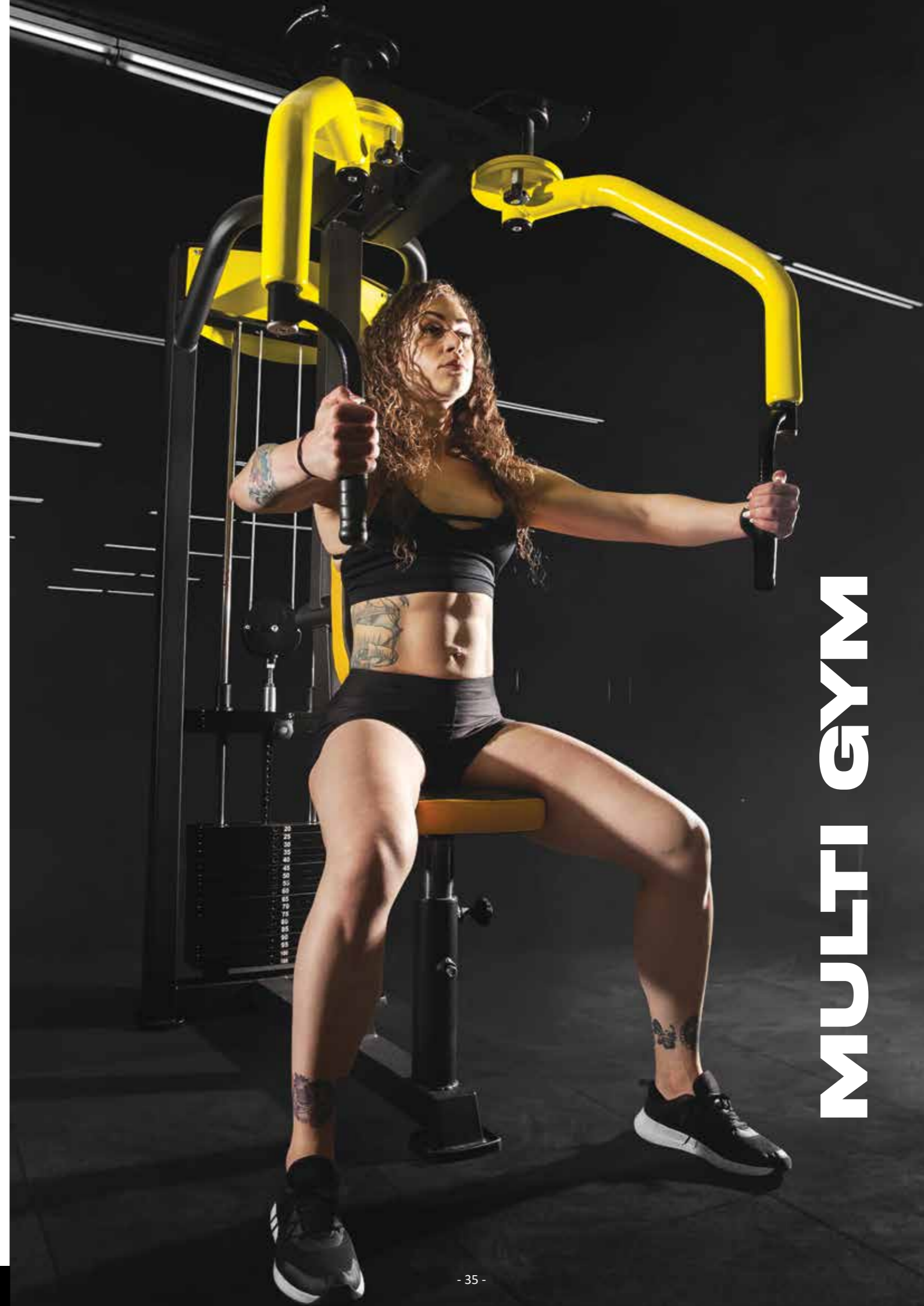

MULTI GYM



SM508

KEY FEATURES

- Biomechanical Design
- Deep Padded Seat and Backrest
- Controlled Angular movement
- Steel Metal Cage for safety
- 2 Weight Stack/5 Station
- FID Bench is an Additional Option

TECHNICAL FEATURES

390 Lbs Metal Weight Stack
Highly Flexible Oil Containing Cable
Key Functions: Tricep Extension, 2000 Lbs Tensile Strength Cable, Lat, Pec Deck, Bench Press, Chest Press, Seated Row, Leg Extension, Preacher Curl, Abductor & Adductor Seated Row, Knee Raise, Single Bar, Bench Press
Machine Floor Size: 82" x 64" x 45"
Maximum user Weight: 170 Kgs
Function: Single Station

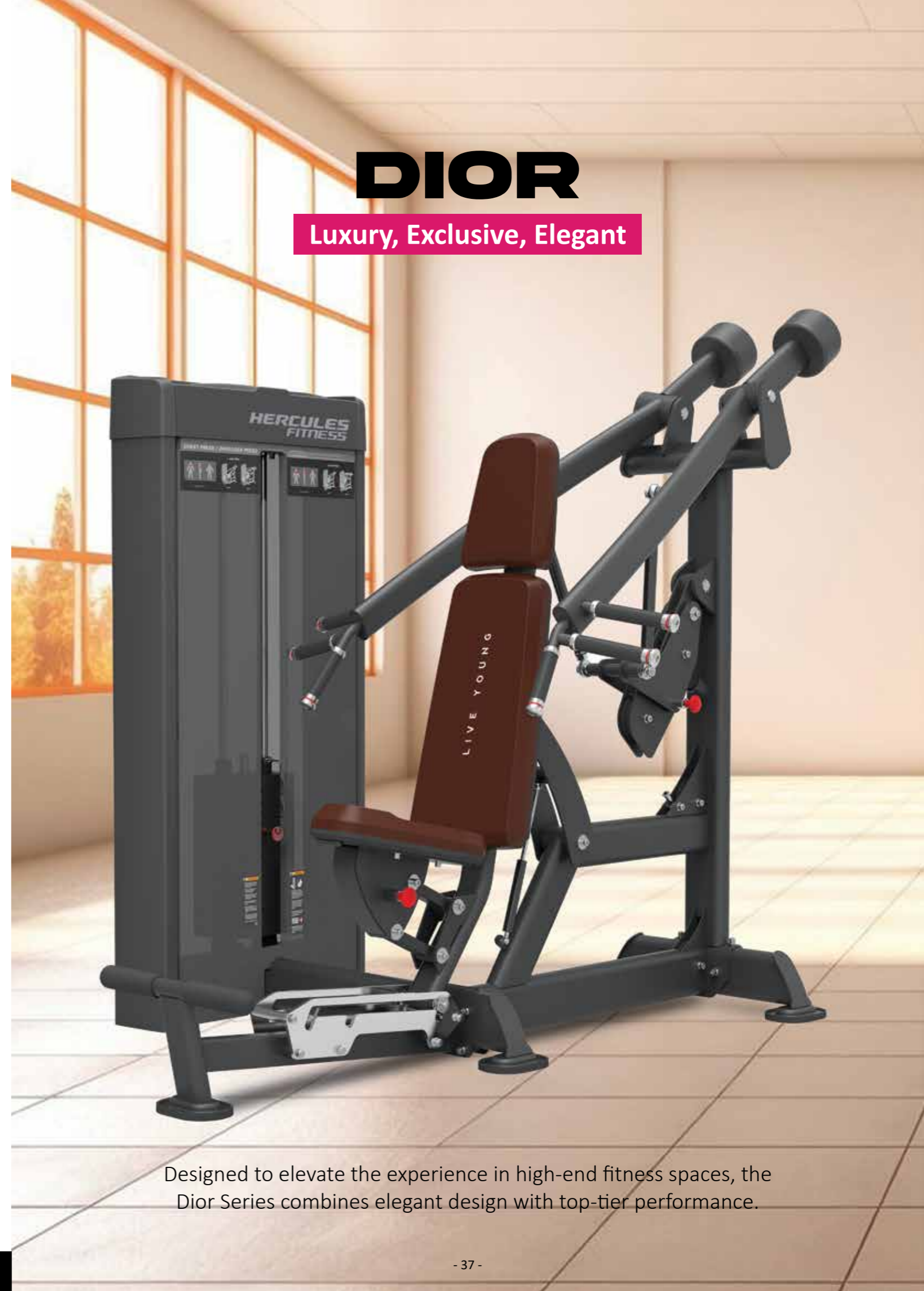

DIOR

Luxury, Exclusive, Elegant

Designed to elevate the experience in high-end fitness spaces, the Dior Series combines elegant design with top-tier performance.



D131 PEC FLY / REAR DELT

Size (inches) 57" x 58" x 78"
 Weight Stack (kg) 105kg
 Weight (kg) 326kg



D132 LAT PULLDOWN / SEATED ROW

Size (inches) 71" x 48" x 90"
 Weight Stack (kg) 105kg
 Weight (kg) 289kg



D125 LEG CURL / LEG EXTENSION

Size (inches) 55" x 49" x 59"
 Weight Stack (kg) 135kg
 Weight (kg) 248kg



D101 SEATED PRESS CHEST

Size (inches) 61" x 39" x 71"
 Weight Stack (kg) 110kg
 Weight (kg) 238kg



D107 BICEP MACHINE

Size (inches) 49" x 43" x 59"
 Weight Stack (kg) 110kg
 Weight (kg) 224kg



D108 TRICEP EXTENSION

Size (inches) 49" x 40" x 59"
 Weight Stack (kg) 110kg
 Weight (kg) 234kg



D114 DIP/CHIN ASSIST

Size (inches) 49" x 47" x 88"
 Weight Stack (kg) 115kg
 Weight (kg) 287kg



D116 HIP ABDUCTOR / ADDUCTOR

Size (inches) 64" x 27" x 59"
 Weight Stack (kg) 115kg
 Weight (kg) 255kg



D121 CHEST PRESS / SHOULDER PRESS

Size (inches) 78" x 54" x 66"
 Weight Stack (kg) 125kg
 Weight (kg) 270kg



D102 SEATED ROW

Size (inches) 63" x 44" x 59"
 Weight Stack (kg) 115kg
 Weight (kg) 243kg



D103 SHOULDER PRESS

Size (inches) 67" x 57" x 59"
 Weight Stack (kg) 110kg
 Weight (kg) 259kg



D113 LAT PULLDOWN

Size (inches) 58" x 48" x 91"
 Weight Stack (kg) 115kg
 Weight (kg) 314kg



D106 LEG CURL

Size (inches) 57" x 50" x 59"
 Weight Stack (kg) 115kg
 Weight (kg) 267kg



D105 LEG EXTENSION ASSISTED

Size (inches) 58" x 50" x 59"
 Weight Stack (kg) 115kg
 Weight (kg) 257kg



D117 CALF EXTENSION

Size (inches) 41" x 38" x 65"
 Weight Stack (kg) 115kg
 Weight (kg) 256kg



D115 HIP TRAINER

Size (inches) 64" x 46" x 59"
 Weight Stack (kg) 115kg
 Weight (kg) 283kg



D112 DELTOID TRAINER

Size (inches) 49" x 49" x 59"
 Weight Stack (kg) 110kg
 Weight (kg) 246kg



D104 TORSO ROTATION

Size (inches) 61" x 49" x 59"
 Weight Stack (kg) 110kg
 Weight (kg) 212kg



D109 ABDOMINAL

Size (inches)	35" × 48" × 59"
Weight Stack (kg)	125kg
Weight (kg)	255kg



D110 BACK EXTENSION

Size (inches)	48" × 48" × 59"
Weight Stack (kg)	125kg
Weight (kg)	258kg



D111 SEATED LEG PRESS

Size (inches)	73" × 47" × 59"
Weight Stack (kg)	150kg
Weight (kg)	346kg



D124 ROTARY HIP

Size (inches)	63" × 55" × 59"
Weight Stack (kg)	85kg
Weight (kg)	225kg



D128 LEG PRESS/CALF EXTENSION

Size (inches)	77" × 45" × 59"
Weight Stack (kg)	170kg
Weight (kg)	297kg



D129 ABDOMINAL/BACK EXTENSION

Size (inches)	52" × 44" × 59"
Weight Stack (kg)	135kg
Weight (kg)	270kg



D130 STANDING CALF EXTENSION

Size (inches)	52" × 46" × 60"
Weight Stack (kg)	125kg
Weight (kg)	267kg



D118 PRONE LEG CURL

Size (inches)	68" × 50" × 59"
Weight Stack (kg)	115kg
Weight (kg)	259kg



D119 LOW ROW

Size (inches)	58" × 40" × 73"
Weight Stack (kg)	125kg
Weight (kg)	243kg



D135 WAIST SIDE BENDING

Size (inches)	54" × 28" × 59"
Weight Stack (kg)	125kg
Weight (kg)	242kg



D137 NECK ROTATION

Size (inches)	54" × 43" × 74"
Weight Stack (kg)	35kg
Weight (kg)	185kg



D138 TORSO ROTATION

Size (inches)	61" × 47" × 79"
Weight Stack (kg)	125kg
Weight (kg)	295kg



D120 GLUTE MACHINE

Size (inches)	35" × 74" × 59"
Weight Stack (kg)	115kg
Weight (kg)	235kg



D122 LATERAL RAISE

Size (inches)	59" × 39" × 59"
Weight Stack (kg)	115kg
Weight (kg)	240kg



D123 NECK BENDING MACHINE

Size (inches)	68" × 28" × 62"
Weight Stack (kg)	90kg
Weight (kg)	230kg



D134 LAT PULLDOWN

Size (inches)	64" × 79" × 81"
Weight Stack (kg)	135kg
Weight (kg)	248kg



D127 BICEPS CURL/TRICEPS EXTENSION

Size (inches)	52" × 43" × 59"
Weight Stack (kg)	100kg
Weight (kg)	235kg



D133 STANDING BICEPS/TRICEPS

Size (inches)	28" × 59" × 83"
Weight Stack (kg)	105kg
Weight (kg)	215kg

ARISTO

Premium, Elite, Sophisticated



Aristo stands for exclusivity, with equipment built to bring both sophistication and advanced functionality to upscale gyms.

ARISTO



AR02A PEC FLY/REAR DELT

Size (inches)	59" x 44" x 81"
Weight Stack (kg)	100kg
Weight (kg)	236kg



AR12A SEATED HORIZONTAL PULLEY

Size (inches)	71" x 41" x 64"
Weight Stack (kg)	100kg
Weight (kg)	199kg



AR1314 DUAL LEG EXTENSION/LEG CURL

Size (inches)	55" x 47" x 65"
Weight Stack (kg)	100kg
Weight (kg)	250kg



AR08 ASSISTED CHIN/DIP

Size (inches)	52" x 56" x 93"
Weight Stack (kg)	100kg
Weight (kg)	293kg



AR1819 DUAL ABDUCTOR/ADDUCTOR

Size (inches)	63" x 39" x 63"
Weight Stack (kg)	100kg
Weight (kg)	240kg



AR13 SEATED LEG CURL

Size (inches)	60" x 49" x 64"
Weight Stack (kg)	100kg
Weight (kg)	266kg



AR14 LEG EXTENSION

Size (inches)	54" x 41" x 64"
Weight Stack (kg)	100kg
Weight (kg)	239kg



AR17 CALF EXTENSION

Size (inches)	63" x 44" x 64"
Weight Stack (kg)	100kg
Weight (kg)	244kg



AR01 CHEST PRESS

Size (inches)	44" x 57" x 67"
Weight Stack (kg)	100kg
Weight (kg)	237kg

ARISTO



AR06 BICEP CURL

Size (inches)	53" x 38" x 64"
Weight Stack (kg)	100kg
Weight (kg)	216kg



AR07 TRICEP PRESS

Size (inches)	54" x 38" x 64"
Weight Stack (kg)	100kg
Weight (kg)	239kg



AR01A CHEST PRESS

Size (inches)	44" x 55" x 64"
Weight Stack (kg)	100kg
Weight (kg)	240kg

ARISTO



AR09 LOWER BACK

Size (inches)	54" x 41" x 67"
Weight Stack (kg)	100kg
Weight (kg)	230kg



AR10 ABDOMINAL CRUNCH

Size (inches)	61" x 40" x 64"
Weight Stack (kg)	100kg
Weight (kg)	215kg



AR04 SEATED ROW

Size (inches)	57" x 35" x 64"
Weight Stack (kg)	100kg
Weight (kg)	232kg



AR03 SHOULDER PRESS

Size (inches)	65" x 57" x 64"
Weight Stack (kg)	100kg
Weight (kg)	243kg



AR12 LAT PULL DOWN/ SEATED ROW

Size (inches)	72" x 58" x 80"
Weight Stack (kg)	100kg
Weight (kg)	249kg



AR11 ROTARY TORSO

Size (inches)	47" x 49" x 64"
Weight Stack (kg)	100kg
Weight (kg)	228kg



AR12C HIGH PULLEY

Size (inches)	54" x 53" x 90"
Weight Stack (kg)	100kg
Weight (kg)	254kg



AR16 MULTI HIP

Size (inches)	45" x 43" x 64"
Weight Stack (kg)	100kg
Weight (kg)	255kg



AR03A DELTS MACHINE

Size (inches)	65" x 59" x 64"
Weight Stack (kg)	100kg
Weight (kg)	200kg



AR02 PEC FLY

Size (inches)	50" x 59" x 64"
Weight Stack (kg)	100kg
Weight (kg)	249kg



AR0910 DUAL LOW BACK WITH ABDOMINAL MACHINE

Size (inches)	49" x 49" x 65"
Weight Stack (kg)	100kg
Weight (kg)	240kg



AR15 LEG PRESS

Size (inches)	77" x 43" x 64"
Weight Stack (kg)	120kg
Weight (kg)	285kg



AR16A STANDING LEG EXTENSION

Size (inches)	45" x 37" x 64"
Weight Stack (kg)	100kg
Weight (kg)	243kg



AR012 DUAL HIGH PULLEY/ROW

Size (inches)	75" x 60" x 83"
Weight Stack (kg)	100kg
Weight (kg)	235kg



AR03 DUAL CHEST PRESS

Size (inches)	77" x 57" x 65"
Weight Stack (kg)	100kg
Weight (kg)	240kg



AR0607 DUAL BICEPS/TRICEPS

Size (inches)	49" x 49" x 65"
Weight Stack (kg)	100kg
Weight (kg)	235kg



AR13A HORIZONTAL LEG CURL

Size (inches)	67" x 40" x 64"
Weight Stack (kg)	100kg
Weight (kg)	240kg

FORGE

Robust, High-Performance, Durable



Built to withstand intense use, the Forge Series is ideal for fitness spaces requiring strong, reliable machines for heavy training.

FORGE



F038 PEC FLY/REAR DELT

Size (inches)	75" x 46" x 81"
Weight Stack (kg)	100kg
Weight (kg)	230kg



F033 LAT PULLDOWN

Size (inches)	63" x 66" x 86"
Weight Stack (kg)	100kg
Weight (kg)	261kg



F028 HORIZONTAL AND SEATED LEG CURL

Size (inches)	50" x 73" x 64"
Weight Stack (kg)	100kg
Weight (kg)	264kg

FORGE



F017 SEATED CALF TRAINERS

Size (inches)	53" x 44" x 64"
Weight Stack (kg)	100kg
Weight (kg)	252kg



F001 CHEST PRESS

Size (inches)	61" x 59" x 64"
Weight Stack (kg)	100kg
Weight (kg)	252kg



F005 BICEPS CURL

Size (inches)	54" x 46" x 64"
Weight Stack (kg)	100kg
Weight (kg)	240kg



F024 DIP/CHIN ASSIST

Size (inches)	62" x 48" x 89"
Weight Stack (kg)	100kg
Weight (kg)	332kg



F019 INNER THIGH ADDUCTOR

Size (inches)	52" x 59" x 64"
Weight Stack (kg)	100kg
Weight (kg)	234kg



F020 OUTER THIGH ABDUCTOR

Size (inches)	52" x 55" x 64"
Weight Stack (kg)	100kg
Weight (kg)	229kg



F006 TRICEP PRESS

Size (inches)	55" x 46" x 64"
Weight Stack (kg)	100kg
Weight (kg)	243kg



F004 PEC FLY/REAR DELT

Size (inches)	59" x 53" x 82"
Weight Stack (kg)	100kg
Weight (kg)	274kg



F003 ROWING MACHINE

Size (inches)	52" x 53" x 64"
Weight Stack (kg)	100kg
Weight (kg)	240kg



F029 MULTI PRESS

Size (inches)	59" x 78" x 64"
Weight Stack (kg)	100kg
Weight (kg)	277kg



F015 PRONE LEG CURL

Size (inches)	64" x 44" x 64"
Weight Stack (kg)	100kg
Weight (kg)	257kg



F013 LEG EXTENSION

Size (inches)	52" x 50" x 64"
Weight Stack (kg)	100kg
Weight (kg)	279kg



F002 SHOULDER PRESS

Size (inches)	78" x 57" x 64"
Weight Stack (kg)	100kg
Weight (kg)	267kg



F008 PULLDOWN

Size (inches)	68" x 62" x 72"
Weight Stack (kg)	100kg
Weight (kg)	286kg



F032 MULTI HIP TRAINER

Size (inches)	47" x 42" x 64"
Weight Stack (kg)	100kg
Weight (kg)	227kg

FORGE



FO12 ROTARY TORSO

Size (inches)	44" x 55" x 64"
Weight Stack (kg)	100kg
Weight (kg)	252kg



FO09 LONG PULL ROW

Size (inches)	69" x 43" x 64"
Weight Stack (kg)	100kg
Weight (kg)	230kg



FO18 REAR KICK

Size (inches)	53" x 39" x 64"
Weight Stack (kg)	100kg
Weight (kg)	222kg

FORGE



FO35 ABDOMINAL

Size (inches)	56" x 53" x 64"
Weight Stack (kg)	100kg
Weight (kg)	230kg



FO36 SEATED DIP

Size (inches)	56" x 47" x 64"
Weight Stack (kg)	100kg
Weight (kg)	240kg



FO14 SEATED LEG CURL

Size (inches)	65" x 50" x 64"
Weight Stack (kg)	100kg
Weight (kg)	298kg



FO39 HIP GLUTE

Size (inches)	61" x 60" x 64"
Weight Stack (kg)	100kg
Weight (kg)	243kg



FO07 LATERAL RAISE

Size (inches)	53" x 52" x 64"
Weight Stack (kg)	100kg
Weight (kg)	237kg



FO26 BICEPS/TRICEPS

Size (inches)	60" x 47" x 64"
Weight Stack (kg)	80kg
Weight (kg)	232kg



FO27 ABDUCTOR/ADDUCTOR

Size (inches)	57" x 52" x 64"
Weight Stack (kg)	100kg
Weight (kg)	244kg



FO30 LAT PULLDOWN/LONG PULL

Size (inches)	63" x 53" x 82"
Weight Stack (kg)	100kg
Weight (kg)	286kg



FO16 LEG PRESS

Size (inches)	78" x 48" x 64"
Weight Stack (kg)	100kg
Weight (kg)	357kg



FO25 SEATED LEG CURL/ EXTENSION

Size (inches)	68" x 49" x 64"
Weight Stack (kg)	100kg
Weight (kg)	294kg



FO10 TOTAL ABDOMINAL

Size (inches)	56" x 44" x 64"
Weight Stack (kg)	100kg
Weight (kg)	247kg



FO11 BACK EXTENSION

Size (inches)	56" x 46" x 64"
Weight Stack (kg)	100kg
Weight (kg)	252kg



FO37 CHEST PRESS (SPLIT)

Size (inches)	57" x 57" x 64"
Weight Stack (kg)	100kg
Weight (kg)	240kg



FO31 ABDOMINAL CRUNCH/ LOWER BACK

Size (inches)	56" x 47" x 64"
Weight Stack (kg)	100kg
Weight (kg)	247kg

DNA

Innovative, Stylish, Premium



The DNA Series brings a modern twist to gym essentials, delivering top quality with a fresh, sleek design.

DNA



DN04 PEC FLY/REAR DELT

Size (inches)	59" x 53" x 82"
Weight Stack (kg)	100kg
Weight (kg)	252.5kg



DN30 LAT PULLDOWN/
LONG PULL

Size (inches)	63" x 53" x 82"
Weight Stack (kg)	100kg
Weight (kg)	258kg



DN13 LEG EXTENSION

Size (inches)	52" x 48" x 64"
Weight Stack (kg)	100kg
Weight (kg)	240kg



DN24 DIP/CHIN ASSIST

Size (inches)	62" x 48" x 89"
Weight Stack (kg)	100kg
Weight (kg)	310kg



DN27 ABDUCTOR/ADDUCTOR

Size (inches)	57" x 52" x 64"
Weight Stack (kg)	100kg
Weight (kg)	242kg



DN29 MULTI PRESS

Size (inches)	59" x 78" x 64"
Weight Stack (kg)	100kg
Weight (kg)	256kg



DN14 SEATED LEG CURL

Size (inches)	65" x 48" x 64"
Weight Stack (kg)	100kg
Weight (kg)	276.5kg



DN25 SEATED LEG CURL/
EXTENSION

Size (inches)	68" x 49" x 64"
Weight Stack (kg)	100kg
Weight (kg)	272kg



DN17 SEATED CALF TRAINERS

Size (inches)	53" x 44" x 64"
Weight Stack (kg)	100kg
Weight (kg)	230kg



DNA01 CHEST PRESS

Size (inches)	61" × 59" × 64"
Weight Stack (kg)	100kg
Weight (kg)	230kg



DNA26 BICEPS/TRICEPS

Size (inches)	60" × 47" × 64"
Weight Stack (kg)	100kg
Weight (kg)	230kg



DNA06 TRICEPS PRESS

Size (inches)	55" × 46" × 64"
Weight Stack (kg)	100kg
Weight (kg)	244kg



DNA09 LONGPULL

Size (inches)	69" × 43" × 64"
Weight Stack (kg)	100kg
Weight (kg)	208kg



DNA08 HIGH PULL DOWN

Size (inches)	68" × 62" × 72"
Weight Stack (kg)	100kg
Weight (kg)	265kg



DNA10 TOTAL ABDOMINAL

Size (inches)	56" × 44" × 64"
Weight Stack (kg)	100kg
Weight (kg)	245kg



DNA03 ROWING MACHINE

Size (inches)	52" × 53" × 64"
Weight Stack (kg)	100kg
Weight (kg)	218kg



DNA02 SHOULDER PRESS

Size (inches)	78" × 57" × 64"
Weight Stack (kg)	100kg
Weight (kg)	245kg



DNA33 Lat Pull Down

Size (inches)	63" × 66" × 86"
Weight Stack (kg)	100kg
Weight (kg)	240kg



DNA16 LEG PRESS

Size (inches)	78" × 48" × 64"
Weight Stack (kg)	100kg
Weight (kg)	335kg



DNA22 ISO LATERAL

Size (inches)	79" × 46" × 64"
Weight Stack (kg)	100kg
Weight (kg)	234kg



DNA15 PRONE LEG CURL

Size (inches)	64" × 44" × 64"
Weight Stack (kg)	100kg
Weight (kg)	235.5kg



DNA07 LATERAL RAISE

Size (inches)	53" × 52" × 64"
Weight Stack (kg)	100kg
Weight (kg)	216kg



DNA31 Abdominal Crunch/
Lower Back

Size (inches)	56" × 46" × 64"
Weight Stack (kg)	100kg
Weight (kg)	234kg



DNA11 BACK EXTENSION

Size (inches)	56" × 46" × 64"
Weight Stack (kg)	100kg
Weight (kg)	245kg



DNA05 ARM CURL

Size (inches)	54" × 46" × 64"
Weight Stack (kg)	100kg
Weight (kg)	239kg



DNA12 ROTARY TORSO

Size (inches)	44" × 55" × 64"
Weight Stack (kg)	100kg
Weight (kg)	260kg

**DN18** REAR KICK

Size (inches)	53" × 39" × 64"
Weight Stack (kg)	100kg
Weight (kg)	242kg

**DN19** INNER THIGH ADDUCTOR

Size (inches)	52" × 59" × 64"
Weight Stack (kg)	100kg
Weight (kg)	257kg

**DN20** OUTER THIGH ABDUCTOR

Size (inches)	52" × 55" × 64"
Weight Stack (kg)	100kg
Weight (kg)	256kg

**DN28** HORIZONTAL AND SEATED LEG CURL

Size (inches)	50" × 73" × 64"
Weight Stack (kg)	100kg
Weight (kg)	242kg

**DN32** MULTI HIP TRAINER

Size (inches)	57" × 48" × 64"
Weight Stack (kg)	100kg
Weight (kg)	241kg

APEX

Efficient, Sleek, Premium



Combining functionality with a streamlined design, the Apex Series is perfect for fitness centers looking to maximize style and efficiency.



AP97 PEC FLY/REAR DELT

Size (inches)	45" × 65" × 83"
Weight Stack (kg)	100kg
Weight (kg)	251kg



AP35 PULLDOWN

Size (inches)	64" × 59" × 77"
Weight Stack (kg)	100kg
Weight (kg)	214kg



AP92 Leg CURL+Leg EXTENSION

Size (inches)	58" × 50" × 58"
Weight Stack (kg)	100kg
Weight (kg)	223kg



AP08 CHEST PRESS

Size (inches)	57" × 55" × 58"
Weight Stack (kg)	100kg
Weight (kg)	205kg



AP30 BICEPS CURL

Size (inches)	49" × 49" × 58"
Weight Stack (kg)	100kg
Weight (kg)	203kg



AP28 SEATED TRICEP EXTENSION

Size (inches)	46" × 49" × 58"
Weight Stack (kg)	100kg
Weight (kg)	205kg



AP09 DIP/CHIN ASSIST

Size (inches)	41" × 53" × 95"
Weight Stack (kg)	100kg
Weight (kg)	252kg



AP93 ABDUCTOR+ADDUCTOR

Size (inches)	29" × 57" × 58"
Weight Stack (kg)	100kg
Weight (kg)	225kg



AP94 MULTI PRESS

Size (inches)	78" × 58" × 58"
Weight Stack (kg)	100kg
Weight (kg)	221kg



AP34 VERTICAL ROW

Size (inches)	51" × 51" × 58"
Weight Stack (kg)	100kg
Weight (kg)	236kg



AP06 SHOULDER PRESS

Size (inches)	48" × 53" × 58"
Weight Stack (kg)	100kg
Weight (kg)	224kg



AP88 LAT PULLDOWN

Size (inches)	58" × 50" × 83"
Weight Stack (kg)	100kg
Weight (kg)	214kg



AP23 SEATED LEG CURL

Size (inches)	56" × 48" × 58"
Weight Stack (kg)	100kg
Weight (kg)	221kg



AP02 LEG EXTENSION

Size (inches)	59" × 50" × 58"
Weight Stack (kg)	100kg
Weight (kg)	213kg



AP11 CALF EXTENSION

Size (inches)	58" × 41" × 58"
Weight Stack (kg)	100kg
Weight (kg)	237kg



AP24 GLUTE ISOLATE

Size (inches)	54" × 37" × 58"
Weight Stack (kg)	100kg
Weight (kg)	213kg



AP05 SEATED LATERAL RAISE

Size (inches)	49" × 56" × 58"
Weight Stack (kg)	100kg
Weight (kg)	225kg



AP26 SEATED DIP

Size (inches)	48" × 46" × 58"
Weight Stack (kg)	100kg
Weight (kg)	227kg



AP90 BICEPS + TRICEPS

Size (inches)	50" x 52" x 58"
Weight Stack (kg)	100kg
Weight (kg)	218kg



AP95 ABDOMINAL CRUNCH+ BACK EXTENSION

Size (inches)	49" x 42" x 58"
Weight Stack (kg)	100kg
Weight (kg)	215kg



AP31 BACK EXTENSION

Size (inches)	48" x 42" x 58"
Weight Stack (kg)	100kg
Weight (kg)	183kg



AP33 LONG PULL

Size (inches)	57" x 46" x 58"
Weight Stack (kg)	100kg
Weight (kg)	180kg



AP19 ABDOMINAL ISOLATOR

Size (inches)	48" x 42" x 58"
Weight Stack (kg)	100kg
Weight (kg)	210kg



AP17 SEATED LEG PRESS

Size (inches)	74" x 44" x 58"
Weight Stack (kg)	100kg
Weight (kg)	240kg



AP15 SHOULDER PRESS

Size (inches)	48" x 58" x 58"
Weight Stack (kg)	100kg
Weight (kg)	210kg



AP01 PRONE LEG CURL

Size (inches)	60" x 43" x 58"
Weight Stack (kg)	100kg
Weight (kg)	199kg



AP03 TORSO ROTARY

Size (inches)	50" x 50" x 58"
Weight Stack (kg)	100kg
Weight (kg)	237kg

STOIC

Resilient, Strong, Premium



Stoic offers premium quality with a focus on strength and resilience, crafted for gyms seeking solid and dependable equipment.



SCS01 PEC FLY & REAR DELT

Size (inches)	41" x 32" x 84"
Weight Stack (kg)	100kg
Weight (kg)	267kg

SCS02 WEIGHT ASSISTED CHIN AND DIP

Size (inches)	67" x 66" x 91"
Weight Stack (kg)	100kg
Weight (kg)	302kg

SCS03 LEG PRESS

Size (inches)	55" x 40" x 92"
Weight Stack (kg)	100kg
Weight (kg)	372kg



SCS04 MULTI PRESS

Size (inches)	60" x 49" x 79"
Weight Stack (kg)	100kg
Weight (kg)	261kg

SCS05 BICEPS & TRICEPS MACHINE

Size (inches)	75" x 52" x 63"
Weight Stack (kg)	100kg
Weight (kg)	233kg

SCS06 LAT PULL DOWN & MID ROW

Size (inches)	84" x 56" x 75"
Weight Stack (kg)	100kg
Weight (kg)	265kg



SCS07 LEG CURL & LEG EXTENSION

Size (inches)	50" x 49" x 63"
Weight Stack (kg)	100kg
Weight (kg)	302kg

SCS08 ADDUCTOR & ABDUCTOR

Size (inches)	54" x 36" x 63"
Weight Stack (kg)	100kg
Weight (kg)	262kg

AURA

Accessible, Modern, Reliable



Aura delivers modern features and accessibility, designed for fitness environments aiming for a balance of quality and reliability.

AURA



AU09 PEC FLY & REAR DELT

Size (inches)	67" x 42" x 79"
Weight Stack (kg)	100kg
Weight (kg)	245kg

AU04 LAT PULL DOWN & MID ROW

Size (inches)	74" x 48" x 76"
Weight Stack (kg)	100kg
Weight (kg)	259kg

AU05 LEG CURL & LEG EXTENSION

Size (inches)	55" x 53" x 64"
Weight Stack (kg)	100kg
Weight (kg)	256kg

AURA



AU10 SHOULDER PRESS

Size (inches)	46" x 43" x 63"
Weight Stack (kg)	100kg
Weight (kg)	219kg

AU14 TRICEPS PRESS

Size (inches)	58" x 61" x 64"
Weight Stack (kg)	100kg
Weight (kg)	181kg

AU15 BICEPS & TRICEPS

Size (inches)	61" x 49" x 73"
Weight Stack (kg)	100kg
Weight (kg)	214kg



AU06 WEIGHT ASSISTED CHIN AND DIP

Size (inches)	68" x 52" x 91"
Weight Stack (kg)	80kg
Weight (kg)	251kg

AU02 ADDUCTOR & ABDUCTOR

Size (inches)	61" x 54" x 64"
Weight Stack (kg)	100kg
Weight (kg)	206kg

AU03 MULTI PRESS

Size (inches)	67" x 54" x 65"
Weight Stack (kg)	100kg
Weight (kg)	245kg



AU11 ABDOMINAL MACHINE

Size (inches)	51" x 48" x 64"
Weight Stack (kg)	100kg
Weight (kg)	201kg

AU12 LATERAL RAISE

Size (inches)	50" x 50" x 64"
Weight Stack (kg)	100kg
Weight (kg)	216kg

AU13 BICEPS CURL

Size (inches)	53" x 50" x 64"
Weight Stack (kg)	100kg
Weight (kg)	205kg



AU01 LEG PRESS

Size (inches)	53" x 58" x 64"
Weight Stack (kg)	100kg
Weight (kg)	186kg

AU07 LEG CURL

Size (inches)	66" x 48" x 64"
Weight Stack (kg)	100kg
Weight (kg)	238kg

AU08 LEG EXTENSION

Size (inches)	57" x 53" x 64"
Weight Stack (kg)	100kg
Weight (kg)	235kg



AU44 STANDING MULTI FLIGHT

Size (inches)	36" x 57" x 81"
Weight Stack (kg)	100kg
Weight (kg)	195kg

GRIT

Compact, Functional, Reliable



Ideal for smaller setups, the Grit Series provides effective training options in a space-saving design.

GRIT



GR02A PEC FLY AND REAR DELT

Size (inches)	65" x 49" x 79"
Weight Stack (kg)	100kg
Weight (kg)	257kg



GR12 LAT PULL DOWN

Size (inches)	49" x 56" x 88"
Weight Stack (kg)	100kg
Weight (kg)	251kg



GR13A LEG CURL

Size (inches)	67" x 47" x 63"
Weight Stack (kg)	100kg
Weight (kg)	245kg



GR14 LEG EXTENSION

Size (inches)	48" x 50" x 63"
Weight Stack (kg)	100kg
Weight (kg)	273kg



GR08 ASSIT DIP CHIN

Size (inches)	51" x 65" x 905"
Weight Stack (kg)	100kg
Weight (kg)	289kg



GR18 INNER THIGH ADDUCTOR

Size (inches)	52" x 56" x 63"
Weight Stack (kg)	100kg
Weight (kg)	240kg



GR19 OUTER THIGH ABDUCTOR

Size (inches)	53" x 49" x 63"
Weight Stack (kg)	100kg
Weight (kg)	241kg



GR16 MULTI HIP

Size (inches)	50" x 52" x 63"
Weight Stack (kg)	100kg
Weight (kg)	252kg



GR15 LEG PRESS

Size (inches)	89" x 49" x 63"
Weight Stack (kg)	100kg
Weight (kg)	263kg



GR13 SEATED LEG CURL

Size (inches)	63" × 50" × 63"
Weight Stack (kg)	100kg
Weight (kg)	266kg



GR17 STANDING CALF

Size (inches)	46" × 50" × 67"
Weight Stack (kg)	100kg
Weight (kg)	256kg



GR01 CHEST PRESS

Size (inches)	46" × 54" × 63"
Weight Stack (kg)	100kg
Weight (kg)	268kg



GR10 ABDOMINAL MACHINE

Size (inches)	50" × 45" × 63"
Weight Stack (kg)	100kg
Weight (kg)	266kg



GR11 TORSO ROTATION

Size (inches)	42" × 51" × 63"
Weight Stack (kg)	100kg
Weight (kg)	238kg



GR04 SEATED ROW

Size (inches)	53" × 49" × 63"
Weight Stack (kg)	100kg
Weight (kg)	239kg



GR03 SHOULDER PRESS

Size (inches)	53" × 55" × 63"
Weight Stack (kg)	100kg
Weight (kg)	229kg



GR16A GLUTE

Size (inches)	89" × 42" × 75"
Weight Stack (kg)	100kg
Weight (kg)	214kg



GR12A LOW ROW

Size (inches)	69" × 45" × 75"
Weight Stack (kg)	100kg
Weight (kg)	227kg



GR1819 HIP ADDUCTOR & ABDUCTOR

Size (inches)	61" × 52" × 63"
Weight Stack (kg)	100kg
Weight (kg)	274kg



GR02 PEC FLY

Size (inches)	48" × 61" × 63"
Weight Stack (kg)	100kg
Weight (kg)	243kg



GR06 BICEPS CURL

Size (inches)	52" × 47" × 63"
Weight Stack (kg)	100kg
Weight (kg)	232kg



GR07 TRICEPS PRESS

Size (inches)	58" × 49" × 63"
Weight Stack (kg)	100kg
Weight (kg)	233kg



GR1314 LEG CURL + EXTENSION

Size (inches)	55" × 53" × 63"
Weight Stack (kg)	100kg
Weight (kg)	270kg

FLEXION

Versatile, Practical, Functional



The Flexion Series offers versatility and reliability, suited for those looking to equip their gyms with essential, high-quality machines.

FLEXION



FX02 REAR DELT & PEC FLY

Size (inches) 60" x 49" x 79"
 Weight Stack (kg) 100kg
 Weight (kg) 200kg



FX1212A ROW & LAT PULL DOWN & STANDING BICEPS

Size (inches) 83" x 45" x 89"
 Weight Stack (kg) 100kg
 Weight (kg) 190kg



FX1314 LEG CURL & LEG EXTENSION

Size (inches) 51" x 49" x 63"
 Weight Stack (kg) 100kg
 Weight (kg) 186kg



FX08 ASSISTED CHIN & DIP & VERTICAL KNEE RAISE

Size (inches) 67" x 66" x 91"
 Weight Stack (kg) 100kg
 Weight (kg) 205kg



FX1819 HIP ADDUCTOR & ABDUCTOR

Size (inches) 70" x 32" x 63"
 Weight Stack (kg) 100kg
 Weight (kg) 190kg



FX03 MULTI PRESS

Size (inches) 75" x 52" x 63"
 Weight Stack (kg) 100kg
 Weight (kg) 185kg



FX13A14 PRONE LEG CURL & SEATED LEG EXTENSION

Size (inches) 62" x 43" x 63"
 Weight Stack (kg) 100kg
 Weight (kg) 205kg



FX1517 LEG PRESS & CALF EXTENSION

Size (inches) 67" x 63" x 63"
 Weight Stack (kg) 100kg
 Weight (kg) 200kg



FX01 MULTI FUNCTIONAL CHEST PRESS

Size (inches) 84" x 56" x 75"
 Weight Stack (kg) 100kg
 Weight (kg) 175kg



FX607 SEATED BICEPS & TRICEPS

Size (inches)	54" x 36" x 63"
Weight Stack (kg)	100kg
Weight (kg)	177kg



FX910 ABDOMINAL & LOWER BACK

Size (inches)	50" x 49" x 63"
Weight Stack (kg)	100kg
Weight (kg)	210kg



FX05 ADJUSTABLE PULLEY

Size (inches)	41" x 32" x 84"
Weight Stack (kg)	100kg
Weight (kg)	165kg



FX607A STANDING BICEPS & TRICEPS

Size (inches)	55" x 40" x 92"
Weight Stack (kg)	100kg
Weight (kg)	175kg



FX016 MULTI HIP

Size (inches)	50" x 44" x 63"
Weight Stack (kg)	100kg
Weight (kg)	205kg

RAZOR

Streamlined, Practical, Efficient



Razor is built for efficiency and ease of use, providing practical functionality in a streamlined design.

RAZOR



RA02A REAR DELT & PEC FLY

Size (inches) 50" x 59" x 78"
 Weight Stack (kg) 100kg
 Weight (kg) 230kg

RA12 LAT PULLDOWN

Size (inches) 59" x 35" x 89"
 Weight Stack (kg) 100kg
 Weight (kg) 220kg

RA13A PRONE LEG CURL

Size (inches) 59" x 37" x 55"
 Weight Stack (kg) 100kg
 Weight (kg) 219kg

RAZOR



RA02 PEC FLY

Size (inches) 50" x 58" x 78"
 Weight Stack (kg) 100kg
 Weight (kg) 240kg

RA04 SEATED ROW

Size (inches) 51" x 35" x 76"
 Weight Stack (kg) 100kg
 Weight (kg) 240kg

RA07 TRICEPS EXTENSION

Size (inches) 45" x 46" x 57"
 Weight Stack (kg) 100kg
 Weight (kg) 215kg



RA14 LEG EXTENSION

Size (inches) 51" x 41" x 65"
 Weight Stack (kg) 100kg
 Weight (kg) 240kg

RA15 LEG PRESS

Size (inches) 74" x 43" x 71"
 Weight Stack (kg) 100kg
 Weight (kg) 350kg

RA1314 LEG CURL / LEG EXTENSION

Size (inches) 52" x 44" x 65"
 Weight Stack (kg) 100kg
 Weight (kg) 260kg



RA10 ABDOMINAL CRUNCH

Size (inches) 60" x 35" x 56"
 Weight Stack (kg) 100kg
 Weight (kg) 220kg

RA10A BACK EXTENSION

Size (inches) 47" x 40" x 56"
 Weight Stack (kg) 100kg
 Weight (kg) 220kg

RA12A LOW ROW

Size (inches) 79" x 33" x 71"
 Weight Stack (kg) 100kg
 Weight (kg) 235kg



RA1819 ADD & ABD STATION

Size (inches) 61" x 30" x 57"
 Weight Stack (kg) 100kg
 Weight (kg) 245kg

RA12A12 LAT PULL DOWN / LOW ROW

Size (inches) 87" x 35" x 89"
 Weight Stack (kg) 100kg
 Weight (kg) 260kg

RA607 BICEPS/TRICEPS

Size (inches) 48" x 43" x 56"
 Weight Stack (kg) 100kg
 Weight (kg) 220kg



RA12T FIXED PULLDOWN

Size (inches) 56" x 53" x 75"
 Weight Stack (kg) 100kg
 Weight (kg) 230kg

RA13 SEATED LEG CURL

Size (inches) 48" x 41" x 65"
 Weight Stack (kg) 100kg
 Weight (kg) 255kg

RA16 MULTI HIP

Size (inches) 69" x 43" x 71"
 Weight Stack (kg) 100kg
 Weight (kg) 245kg

RAZOR



RA17 STANDING CALF

Size (inches)	55" x 44" x 73"
Weight Stack (kg)	80kg
Weight (kg)	235kg



RA18 HIP ADDUCTOR

Size (inches)	60" x 29" x 56"
Weight Stack (kg)	100kg
Weight (kg)	230kg



RA910 ABDOMINAL CRUNCH/
LOWER BACK

Size (inches)	46" x 41" x 56"
Weight Stack (kg)	100kg
Weight (kg)	210kg



RA03 SHOULDER PRESS

Size (inches)	55" x 57" x 65"
Weight Stack (kg)	100kg
Weight (kg)	231kg



RA03A LATERAL RAISE

Size (inches)	45" x 41" x 65"
Weight Stack (kg)	100kg
Weight (kg)	240kg



RA03B MULTI PRESS

Size (inches)	74" x 56" x 65"
Weight Stack (kg)	100kg
Weight (kg)	278kg



RA06 BICEPS CURL

Size (inches)	45" x 44" x 56"
Weight Stack (kg)	100kg
Weight (kg)	200kg



RA08 ASSISTED CHIN-UP / DIP

Size (inches)	48" x 45" x 87"
Weight Stack (kg)	100kg
Weight (kg)	295kg



RA01 CHEST PRESS

Size (inches)	59" x 43" x 65"
Weight Stack (kg)	100kg
Weight (kg)	245kg

ARMOUR

Durable, Reliable, Resilient



Built for durability and resilience, the Armour Series offers reliable performance for the toughest workouts. Ideal for high-performance training spaces.



ARO0 CALF MACHINE

Size (inches) 73" x 48" x 48"
Weight (kg) 171kg



ARO1 CHEST PRESS

Size (inches) 73" x 54" x 68"
Weight (kg) 160kg



ARO2 INCLINE CHEST PRESS

Size (inches) 65" x 46" x 67"
Weight (kg) 153kg



ARO3 SHOULDER PRESS

Size (inches) 55" x 47" x 62"
Weight (kg) 137kg



ARO4 LOW ROW

Size (inches) 58" x 52" x 66"
Weight (kg) 143kg



ARO5 WIDE CHEST PRESS

Size (inches) 73" x 56" x 71"
Weight (kg) 165kg



ARO6 ROW MACHINE

Size (inches) 57" x 48" x 52"
Weight (kg) 127kg



ARO7 PULL DOWN

Size (inches) 68" x 46" x 77"
Weight (kg) 144kg



ARO8 REAR KICK

Size (inches) 60" x 45" x 64"
Weight (kg) 132kg



ARO9 LEG PRESS

Size (inches) 80" x 76" x 67"
Weight (kg) 224kg



ARO10 BICEPS

Size (inches) 42" x 50" x 39"
Weight (kg) 100kg



ARO11 SEATED LEG EXTENSION

Size (inches) 53" x 53" x 49"
Weight (kg) 98kg



ARO12 TRICEPS PRESS

Size (inches) 64" x 65" x 42"
Weight (kg) 145kg



ARO13 STANDING LEG CURL

Size (inches) 48" x 49" x 54"
Weight (kg) 99kg

STOIC

Strong, Steadfast, Relentless



The Stoic Series delivers unwavering performance with a focus on strength and stability, designed for those who push their limits.

STOIC



SCP01	LATERAL BENCH PRESS
Size (inches)	63" x 50" x 81"
Weight (kg)	140kg



SCP02	LATERAL DECLINE CHEST PRESS
Size (inches)	65" x 46" x 80"
Weight (kg)	130kg



SCP03	ABDOMINAL OBLIQUE CRUNCH
Size (inches)	73" x 41" x 55"
Weight (kg)	126kg



SCP04	CHEST PRESS & LATPUL DOWN
Size (inches)	85" x 70" x 79"
Weight (kg)	172kg



SCP05	MULTI BELT SQUAD
Size (inches)	96" x 61" x 60"
Weight (kg)	78kg



SCP06	LATERAL STANDING PEC FLY
Size (inches)	47" x 50" x 61"
Weight (kg)	95kg



SCP07	LATERAL STANDING LATER RAISE
Size (inches)	47" x 44" x 53"
Weight (kg)	142kg



SCP08	LATERAL CROSS LAT PULL DOWN
Size (inches)	61" x 51" x 73"
Weight (kg)	135kg

AURA

Elegant, Sophisticated, Powerful



The Aura Series combines sleek design with powerful functionality, creating an exceptional experience for premium fitness spaces.

AURA



AU27 BELT SQUAD

Size (inches)	63" x 38" x 46"
Weight (kg)	73kg



AU17 HACK SQUAT

Size (inches)	94" x 64" x 57"
Weight (kg)	212kg



AU19 LEG PRESS

Size (inches)	95" x 64" x 57"
Weight (kg)	232kg



AU20 SUPER SQUAT

Size (inches)	88" x 63" x 50"
Weight (kg)	203kg



AU21 CHEST PRESS

Size (inches)	67" x 42" x 79"
Weight (kg)	132kg



AU18 LEG PRESS & HACK SQUAT

Size (inches)	97" x 73" x 60"
Weight (kg)	232kg



AU25 MULTI FUNCTION BELT SQUAD

Size (inches)	67" x 41" x 62"
Weight (kg)	145kg



AU26 ABDOMINAL MACHINE

Size (inches)	46" x 43" x 63"
Weight (kg)	115kg



AU22 LOW ROW

Size (inches)	65" x 55" x 52"
Weight (kg)	123kg



AU23 ROW

Size (inches)	63" x 61" x 60"
Weight (kg)	121kg



AU24 SHOULDER PRESS

Size (inches)	52" x 55" x 67"
Weight (kg)	129kg

FUNCTIONAL, CABLE, SMITH & MULTI STATION





D112B CROSSOVER PULLEY COMBO

Size (inches)	102" × 29" × 92"
Weight Stack (kg)	220kg
Weight (kg)	388kg



D1950 FUNCTIONAL GYM (SMITH+CABLE CROSS)

Size (inches)	93" × 54" × 85"
Weight Stack (kg)	100×2kg
Weight (kg)	442kg



D1921 FUNCTIONAL TRAINER

Size (inches)	60*33*83
Weight Stack (kg)	100x2kg
Weight (kg)	319kg



EC05 CABLE CROSSOVER

Size (inches)	137" x 50" x 93"
Weight Stack (kg)	100 x 2kg
Weight (kg)	320kg



D1920 SMITH MACHINE

Size (inches)	84" x 50" x 85"
Weight (kg)	188kg

EC20B SMITH AND FUNCTIONAL TRAINER

Size (inches)	97" x 59" x 89"
Weight Stack (kg)	100 x 2kg
Weight (kg)	345kg



AU45 SMITH & FUNCTIONAL TRAINER

Size (inches)	89" x 47" x 83"
Weight Stack (kg)	100x2kg
Weight (kg)	395kg



EC05A FUNCTIONAL TRAINER

Size (inches)	61" x 47" x 95"
Weight Stack (kg)	100 x 2kg
Weight (kg)	380kg

AU46 ADJUSTABLE CABLE CROSS OVER

Size (inches)	154" x 27" x 87"
Weight Stack (kg)	100x2kg
Weight (kg)	640kg



FUNCTIONAL, CABLE, SMITH & MULTI STATION



AU47 FUNCTIONAL TRAINER

Size (inches)	66" x 47" x 88"
Weight Stack (kg)	100x2kg
Weight (kg)	395kg

FUNCTIONAL, CABLE, SMITH & MULTI STATION



AU52 SMITH MACHINE

Size (inches)	87" x 54" x 87"
Weight Stack (kg)	100x2kg
Weight (kg)	210kg



AU48 POWER RACK

Size (inches)	71" x 69" x 91"
Weight (kg)	170kg

AU53 POWER CAGE WITH SMITH MACHINE

Size (inches)	88" x 75" x 86"
Weight (kg)	284kg





AB89 SMITH AND FUNCTIONAL TRAINER AND SUPER RACK

Size (inches)	76" x 66" x 91"
Weight Stack (kg)	100x2kg
Weight (kg)	370kg

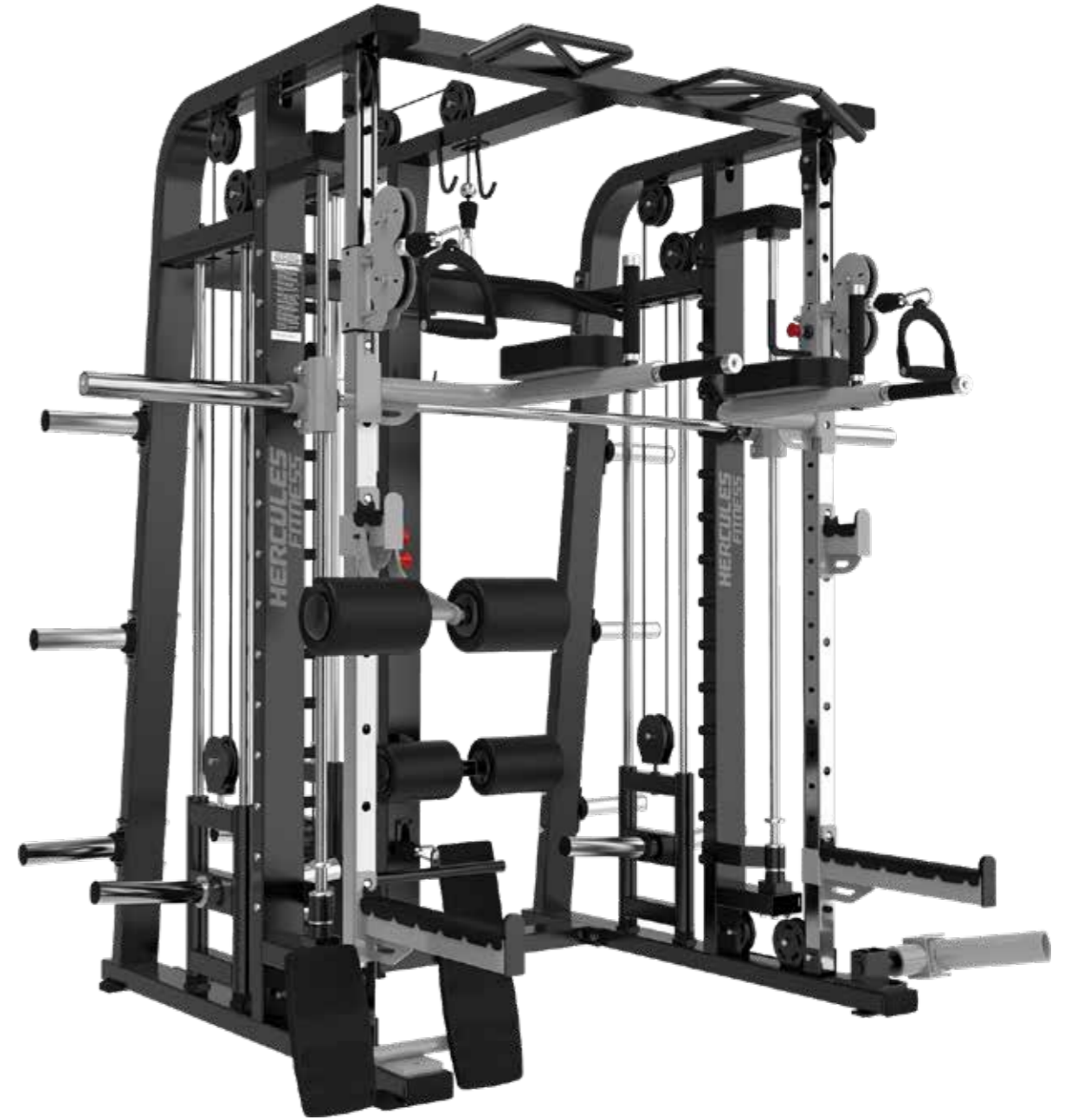

AZ93 SMITH AND MULTI FUNCTIONAL TRAINER

Size (inches)	87" x 87" x 87"
Weight (kg)	390kg



AB15 ADJUSTABLE CABLE CROSSOVER

Size (inches)	163" x 40" x 91"
Weight Stack (kg)	100x2kg
Weight (kg)	370kg



AB73 3D SMITH MACHINE

Size (inches)	87" x 86" x 50"
Weight (kg)	265kg

AB17 FUNCTIONAL TRAINER

Size (inches)	41" x 77" x 91"
Weight Stack (kg)	100x2kg
Weight (kg)	370kg



AB63 SMITH MACHINE

Size (inches)	86" x 64" x 50"
Weight (kg)	284kg





AB87 SMITH AND SQUAT

Size (inches)	88" × 76" × 86"
Weight (kg)	248kg

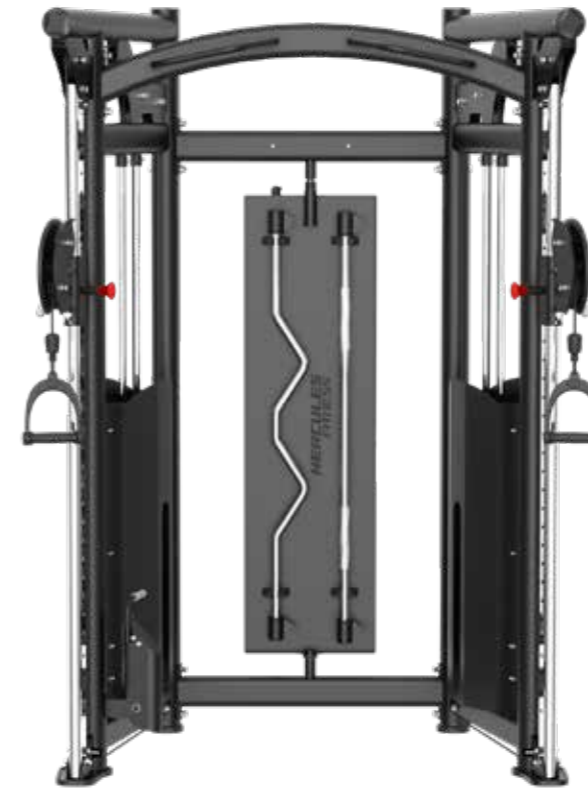

FU05A MULTI STATION FUNCTIONAL TRAINER

Size (inches)	66" × 45" × 91"
Weight Stack (kg)	100 × 2kg
Weight (kg)	365kg



AZ73 FUNCTIONAL SQUAT RACK

Size (inches)	69" × 68" × 90"
Weight (kg)	175kg

FU20B MULTI STATION SMITH AND FUNCTIONAL TRAINER

Size (inches)	97" × 59" × 89"
Weight Stack (kg)	100 × 2kg
Weight (kg)	405kg





FU05 DUAL STATION CABLE CROSSOVER

Size (inches)	136" × 40" × 93"
Weight Stack (kg)	100 × 2kg
Weight (kg)	350kg



CROSS FIT 360 MULTI FUNCTION MACHINE

Machine Weight: 955kg

Accessories: TRX, Battle Rope, Resistance band 01, Agility ladder, Resistance band 02, Training Belt, Medicine Ball, Kettle Ball, Punching bag, Punching glove, Bandage, Bosu Ball, Trampoline, Fitness ball 03

FREE WEIGHT & BENCHES



ECLIPSE



EC01 MULTI FUNCTIONAL PRESS

Size (inches)	67" x 76" x 65"
Weight (kg)	333kg

AZ83 CHEST PUSHER

Size (inches)	70" x 77" x 68"
Weight (kg)	120kg





EC23A OLYMPIC FLAT BENCH

Size (inches) 51" x 64" x 53"
Weight (kg) 61kg



EC25A OLYMPIC INCLINE BENCH

Size (inches) 91" x 75" x 62"
Weight (kg) 83.5kg



EC24A OLYMPIC DECLINE BENCH

Size (inches) 79" x 60" x 47"
Weight Stack (kg) 150kg



EC37 MULTI ADJUSTABLE BENCH (FLAT/INCLINE/DECLINE)

Size (inches) 63" x 29" x 45"
Weight (kg) 38.5kg



EC38 UTILITY BENCH

Size (inches) 45" x 25" x 43"
Weight (kg) 27kg



EC25B VERTICAL BENCH

Size (inches) 70" x 64" x 72"
Weight (kg) 142kg



EC02 GLUTE HAM DEVELOPER

Size (inches) 56" x 33" x 46"
Weight (kg) 83kg



EC21 SQUAT RACK

Size (inches) 76" x 64" x 81"
Weight (kg) 138kg



EC26A HYPER EXTENSION

Size (inches) 52" x 27" x 32"
Weight (kg) 41.5kg



EC29 SEATED CALF MACHINE

Size (inches) 50" x 30" x 31"
Weight (kg) 45kg



EC40 PREACHER CURL

Size (inches) 43" x 32" x 37"
Weight (kg) 47kg



AZ02 FLIP TYRE

Size (inches) 65" x 49" x 24"
Weight (kg) 142kg

AB39 SUPER BENCH WITH CUSHION SADDLE

Size (inches) 52" x 26" x 28"
Weight (kg) 38kg

AB50 SQUAT RACK

Size (inches) 69" x 61" x 71"
Weight (kg) 111kg



FU22 45 DEGREE INCLINE SQUAT MACHINE

Size (inches) 91" x 63" x 58"
Weight (kg) 299kg

FU26A HYPER EXTENSION

Size (inches) 49" x 26" x 32"
Weight (kg) 42kg



AB54 VERTICAL PLATE TREE

Size (inches) 23" x 26" x 51"
Weight (kg) 25kg

AB56 45 DEGREE LEG PRESS

Size (inches) 86" x 64" x 50"
Weight (kg) 215kg

AB59 45 DEGREE LEG PRESS AND HACK SQUAT

Size (inches) 93" x 64" x 57"
Weight (kg) 254kg



FU34 ADJUSTABLE WEB BOARD

Size (inches) 73" x 28" x 36"
Weight (kg) 63kg

FU29 SEATED CALF MACHINE

Size (inches) 53" x 21" x 37"
Weight (kg) 57kg



AZ30 HIP THRUSTER

Size (inches) 56" x 65" x 31"
Weight (kg) 79kg

AZ31 GLUTE HAM BENCH

Size (inches) 63" x 36" x 39"
Weight (kg) 70kg

FU30 2 TIER DUMBBELL RACK WITH SADDLE

Size (inches) 92" x 33" x 34"
Weight (kg) 32kg

FU33 STRETCH TRAINER

Size (inches) 53" x 19" x 35"
Weight (kg) 32kg

AURA



AU32 OLYMPIC FLAT BENCH

Size (inches) 65" x 60" x 47"
Weight (kg) 150kg



AU31 OLYMPIC INCLINE BENCH

Size (inches) 73" x 61" x 56"
Weight (kg) 150kg



AU30 OLYMPIC DECLINE BENCH

Size (inches) 79" x 60" x 47"
Weight (kg) 150kg

AURA



AU34 MULTI ADJUSTABLE BENCH

Size (inches) 70" x 33" x 19"
Weight (kg) 140kg



AU35 HYPER EXTENSION

Size (inches) 31" x 27" x 34"
Weight (kg) 140kg



AU29 OLYMPIC FID BENCH

Size (inches) 91" x 64" x 60"
Weight (kg) 103kg



AU37 UTILITY BENCH

Size (inches) 43" x 21" x 36"
Weight (kg) 140kg



AU36 PREACHER CURL

Size (inches) 39" x 18" x 41"
Weight (kg) 150kg



AU38 FLAT BENCH

Size (inches) 55" x 21" x 17"
Weight (kg) 150kg



AU39 VERTICAL PLATE TREE

Size (inches) 31" x 20" x 42"
Weight (kg) 17kg



AU16 HAND WRIST CURL

Size (inches) 19" x 24" x 36"
Weight (kg) 80kg



AU28 SEATED CALF RAISE

Size (inches) 48" x 28" x 34"
Weight (kg) 140kg



AU33 MULTI ADJUSTABLE WEB BOARD

Size (inches) 72" x 29" x 37"
Weight (kg) 50kg



AU40 3 TIER DUMBBELL RACK WITH SADDLE

Size (inches) 93" x 32" x 33"
Weight (kg) 67kg



AU54 T-ARM MACHINE

Size (inches) 78" x 31" x 30"
Weight (kg) 60kg



AU41 FIXED BARBELL RACK

Size (inches) 44" x 31" x 56"
Weight (kg) 40kg

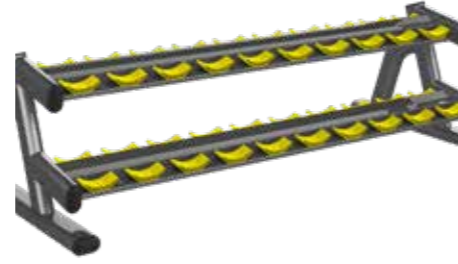

AU42 2 TIER DUMBBELL RACK (PAIR)

Size (inches) 93" x 24" x 31"
Weight (kg) 66kg



AU43 VERTICAL KNEE RAISE

Size (inches) 44" x 58" x 91"
Weight (kg) 150kg



AU49 INCLINE T BAR

Size (inches) 39" x 69" x 46"
Weight (kg) 70kg



AU50 POWER SMITH MACHINE DUAL SYSTEM

Size (inches) 81" x 87" x 59"
Weight (kg) 244kg



AC60 AB COASTER

Size (inches) 26" x 75" x 57"
Weight (kg) 67kg



WA23A OLYMPIC FLAT BENCH

Size (inches) 54" x 48" x 47"
Weight (kg) 61kg



WA24A OLYMPIC DECLINE BENCH

Size (inches) 63" x 48" x 47"
Weight (kg) 108kg



WA25A OLYMPIC INCLINE BENCH

Size (inches) 63" x 48" x 60"
Weight (kg) 84kg



WA36A FLAT BENCH

Size (inches) 59" x 28" x 17"
Weight (kg) 33kg



WA38 UTILITY BENCH

Size (inches) 41" x 20" x 42"
Weight (kg) 27kg



WA40 PREACHER CURL

Size (inches) 41" x 28" x 38"
Weight (kg) 40kg

ACCESSORIES

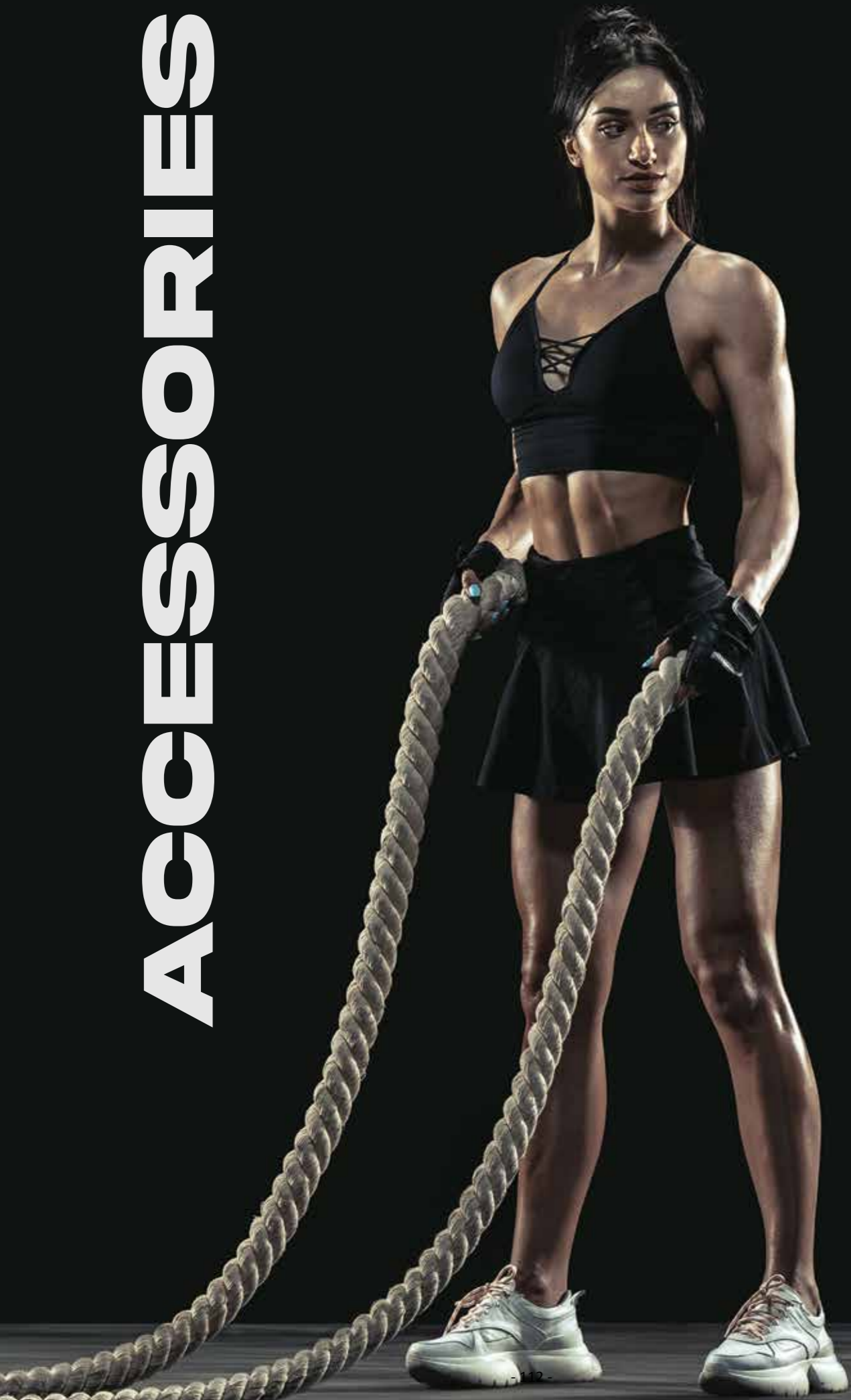

ACCESSORIES



BOUNCER DUMBBELS
2.5kg, 5kg, 7.5kg, 10kg, 12.5kg, 15kg,
17.5kg, 20kg, 25kg, 30kg



HEXAGON DUMBBELS
2.5kg, 5kg, 7.5kg, 10kg, 12.5kg



TPU DUMBBELS
2.5kg, 5kg, 7.5kg, 10kg, 12.5kg, 15kg,
17.5kg, 20kg, 25kg, 30kg



**WEIGHT PLATE 29 MM
REGULAR ROD**
2.5kg, 5kg, 7.5kg, 10 kg



**WEIGHT PLATE 51 MM
OLYMPIC ROD**
2.5kg, 5kg, 7.5kg, 10kg, 12.5kg, 15kg,
17.5kg, 20kg, 25kg



**WEIGHT PLATE
51 MM-TPU**
2.5kg, 5kg, 10kg, 15kg, 20kg, 25kg



BUMPER PLATE 51 MM
5kg, 10kg, 15kg, 20kg, 25kg



**WEIGHT PLATE 29 MM
DUMBBELL ROD**
1kg, 2kg, 2.5kg, 5kg, 7.5kg, 10kg



STRAIGHT BARBELL
10kg, 15kg, 20kg, 25kg, 30kg



CURL BARBELL
10kg, 15kg, 20kg, 25kg, 30kg



**HERCULES-FOLDABLE
EXERCISE MAT-180*60*4CM**



JUMP ROPE



**JUMP ROPE-FOAM
HANDLE-2750 MM**



HAND GRIP-WITH FOAM



**AEROBIC STEP-CLASSIC-
68X28.5X10/15CM**

ACCESSORIES



ADJUSTABLE AEROBIC STEP—PREMIUM—72X35X10/15/20CM



PUSH UP BAR



MULTI ASSISTANCE TRAINING KIT



HERCULES—WALLBALL

4kg, 5kg, 7kg



COLLAR—50MM—FAST LOCKED TYPE



HERCULES—MEDICINEBALL

3kg, 4kg, 5kg, 6kg, 8kg, 10kg



DUMBBELL ROD—WITH LOCK SYSTEM



HERCULES—COLLAR SPRING—28MM DIA



REGULAR ROD

28x1524mm, 28x1828mm, 28x2184mm



EZ CURL ROD—28X1200MM



OLYMPIC BAR—50MM DIA

4 Feet, 5 Feet, 6 Feet, 7 Feet



OLYMPIC TRICEPS BAR—3 FEET—28MM



OLYMPIC CURL BAR—4 FEET—EZ—28MM DIA



GYM BALL—WITH AIR PUMP

55cm, 65cm, 75cm, 85cm



YOGA MAT

Classic-1cm-173x61cm
Premium-1cm-183x61cm
Hercules Yoga Mat-Classic-1.5cm-173x61cm
Hercules Yoga Mat-Premium-1.5cm-183x61cm

HERCULES | **EXPERIENCE CENTRE**
FITNESS
LIVE YOUNG



SCAN & WATCH



SCAN & DOWNLOAD THE CATALOGUE

HERCULES

FITNESS

LIVE YOUNG



murugappa

Register address:

Tube Investments of India Ltd.

“Chola Crest”, C54 & 55, Super B-4, Thiru Vi Ka Industrial Estate, Guindy, Chennai - 600 032.

Phone: +91 44 4217 7770 - 75 | Fax: +91 44 4211 0404

Email: info@tii.murugappa.com | info@tii.murugappa.com

Factory: TI Cycles of India (A unit of Tube Investments of India Ltd.,)

Post Bag No. 5, MTH Road, Ambattur, Chennai - 600 053.

<https://herculesfitness.co.in> | customercare@bsahercules.com | Toll-free no.: 1800 102 2324

Contact our Zonal Head for Enquiries:

North: +91 8299066007 | East: +91 9475118117 | West: +91 8308834408 | South: +91 9789033476

Disclaimer: Innovation is a continuous process at TI Cycles of India. Specifications, features, colors and prices are likely to change without prior notice. Accessories shown in the pictures may or may not be part of the standard equipment.

Dealer Address & Stamp: